

PART NAME	EXTRUDED ALUMINUM BOX	PART No.	EX-4521 & EX-4522 & EX-4523
-----------	-----------------------	----------	-----------------------------

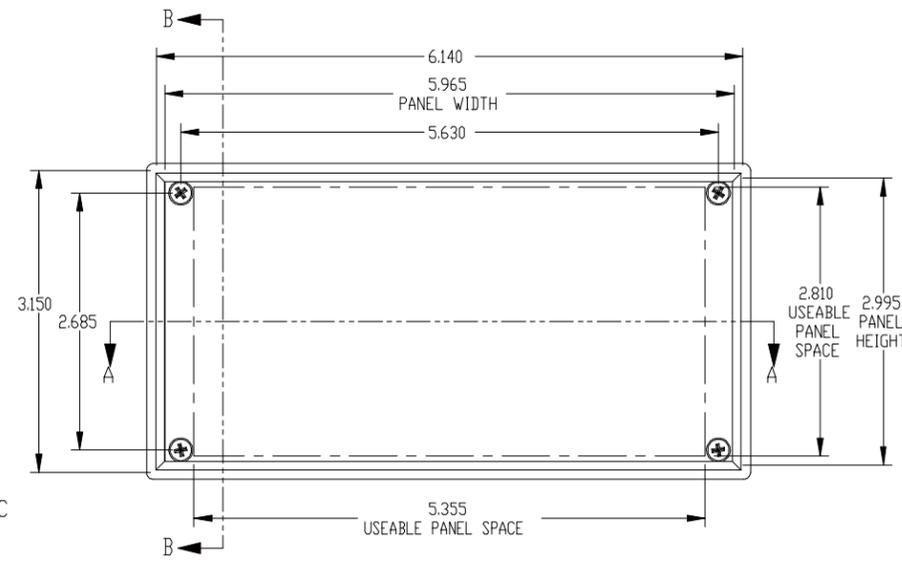
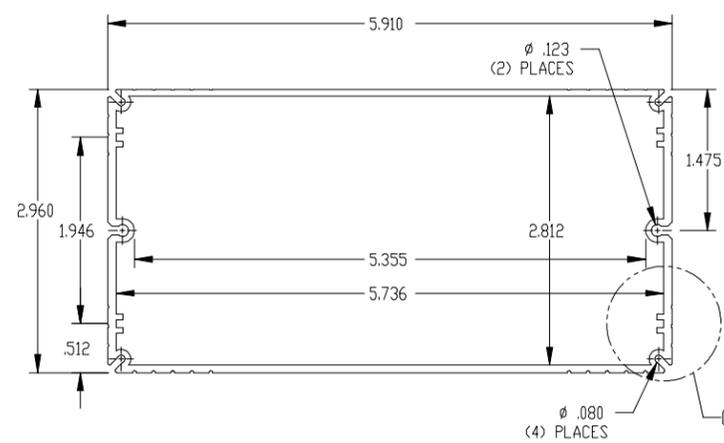
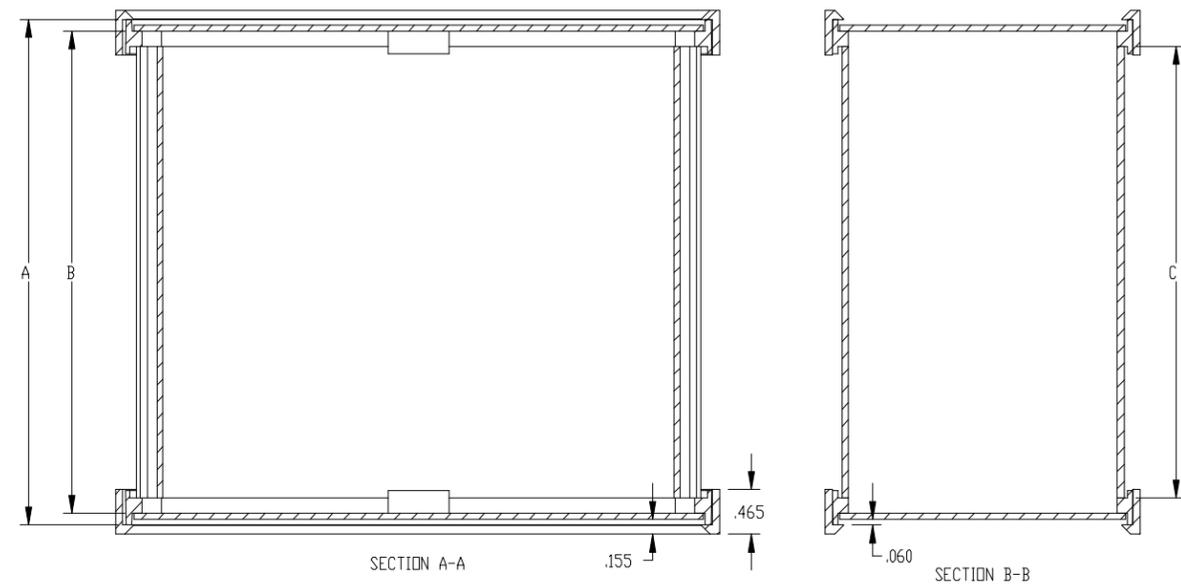
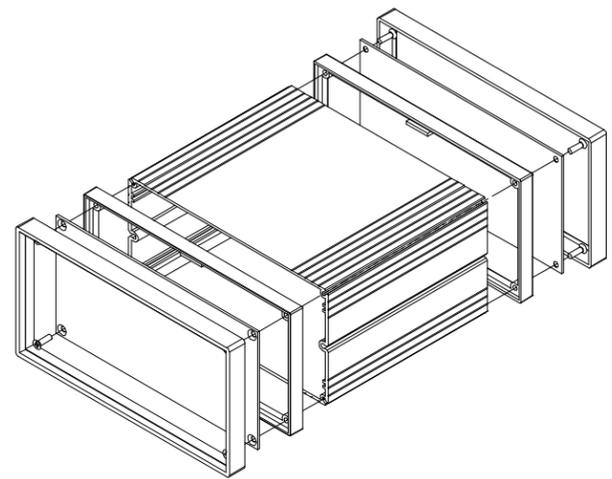

MATERIAL:  
 BODY - ALUMINUM  
 BEZEL - UL94V-0 ABS  
 PANEL - .060 THK. ALUMINUM

FINISH:  
 BODY - SILVER COATING  
 BEZEL - BLACK  
 PANEL - NATURAL

EIGHT (8) M3 x 10mm FLAT HEAD SCREWS SUPPLIED TO ATTACH END PANELS AND BEZELS TO BODY (ALTERNATE SCREW #4 x 5/8 FLAT HEAD THREAD CUTTING SCREWS CAN BE SUBSTITUTED) RECOMMEND INSERTION TORQUE 6-8 in-lbs.

ALL DIMENSIONS HAVE ±.015 TOLERANCE UNLESS OTHERWISE SPECIFIED

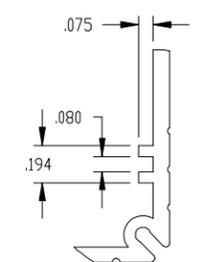

PART No.	INTERNAL CLEARANCE		
	A	B	C
EX-4521	5.38	5.14	4.82
EX-4522	6.96	6.72	6.40
EX-4523	9.26	9.02	8.66